

OBJECT RECOGNITION AND TRACKING USING 3D LASER SCANNERS MOUNTED ON A CONSTRUCTION VEHICLE

Gai Ozaki*¹, Masafumi Nakagawa¹, Masahiro Miyo²

¹Graduate Student, Department of civil engineering, Shibaura Institute of Technology
3-7-5, Toyosu, Koto-ku, Tokyo, 135-8548, Japan
Email: ah18020@shibaura-it.ac.jp

²Co-researcher, Watanabe Engineering Co., Ltd.
7-4-69, Noda-tyo, Fukushima City, Fukushima, 960-8055, Japan
Email: mim@watanabe-office.jp

KEY WORDS: Point Cloud, Laser Scanning, Object Recognition, Object Tracking, Construction Vehicle

ABSTRACT: In recent years, the construction industry has started using ICT construction vehicles to improve the productivity of construction projects for technical issues such as worker shortages. Although ICT construction vehicles can be fully utilized in unmanned construction environments, applying conventional ICT construction vehicles is difficult in dense urban areas. In our related research, we developed a visualization of construction space safety by recognizing and identifying workers from horizontal laser scanning data acquired by a LiDAR mounted on a construction vehicle in collaborative construction work with workers. However, the horizontal scanning data were insufficient to detect objects due to the narrow range of vertical scanning angles. Therefore, we proposed a method to integrate two-point cloud data acquired by horizontal and vertical LiDAR. The integration of the horizontal and vertical LiDAR point clouds is performed using vertical LiDAR's rotation correction, tilt correction, and alignment with offset values. We also proposed a method to recognize backhoe buckets and workers working in the construction space from the integrated point cloud. Then, we proposed a method to track the point clouds recognized as workers. In this study, experiments of visualization, object recognition, and tracking were conducted during excavation work by a backhoe in a simulated construction space. As a result, we confirmed that the bucket can be recognized using point cloud data acquired from a backhoe during excavation work. We also evaluated the performance of representation and object recognition and tracking in construction by comparing the integrated vertical and horizontal LiDAR point clouds.

1. INTRODUCTION

In the current construction industry, various efforts and projects are underway to develop and introduce advanced construction vehicles equipped with ICT technology and building information modeling (BIM) to improve productivity, reduce accidents, and realize manpower-saving construction for entire construction projects. In large-scale construction spaces, construction experiments using remotely operated unmanned construction vehicles are being conducted to improve productivity and safety by utilizing the BIM/CIM framework. Remote-operated unmanned construction replaces backhoe operations in space by improving the work environment with a joystick-type remote control and a monitor covering a wide viewing angle (Kajita et al., 2017). Taisei Corporation tested a camera system at Unzen Fugendake (Kondo et al., 2011). The operator's viewpoint is shared with a mobile remote-control room using an onboard camera attached to the operator's seat of the construction equipment. This assists the operator to quickly evacuate to a safe location in the event of a landslide or other emergency. Kajima Corporation has also been conducting demonstration tests of construction vehicles using ICT technology at unmanned construction spaces since 2005; in 2018, full-scale unmanned construction was implemented at a dam construction site. Although the construction vehicles are not operated remotely, instructions from the control room are sent to multiple construction vehicles to perform unmanned construction (Kajima Corporation, 2020). In addition, although various ICT construction vehicles have been developed in the past, several technical issues remain for collaboration with workers. In small-scale construction spaces in urban areas, it is difficult to apply existing ICT construction equipment, and construction vehicles need to work collaboratively with workers to perform detailed tasks such as excavation and drilling work. Previous studies have attempted to visualize the safety of construction spaces by object recognition and tracking from horizontal scanning data using multilayer LiDAR. However, horizontal scanning has problems such as insufficient vertical scanning angle, making it difficult to grasp the bucket behavior, and insufficient scanning resolution, causing object detection omissions and difficulties. Therefore, this study constructs a system that additionally mounts a vertical LiDAR to the horizontal LiDAR and develops an object recognition method using point cloud data acquired by vertical scanning. The objectives of this study are to develop a measurement system that combines horizontal LiDAR and vertical LiDAR scanning, a method for integrating point clouds acquired by each LiDAR, and an object recognition and tracking method using the integrated results. The objectives of this project are to develop a measurement system that combines horizontal and vertical LiDAR.

2. METHODOLOGY

The proposed methodology in this study is shown in Figure 1. It consists of time synchronization of LiDAR, point cloud integration of vertical and horizontal LiDAR, ground surface estimation by the RANSAC algorithm, backhoe bucket recognition, and worker recognition and tracking.

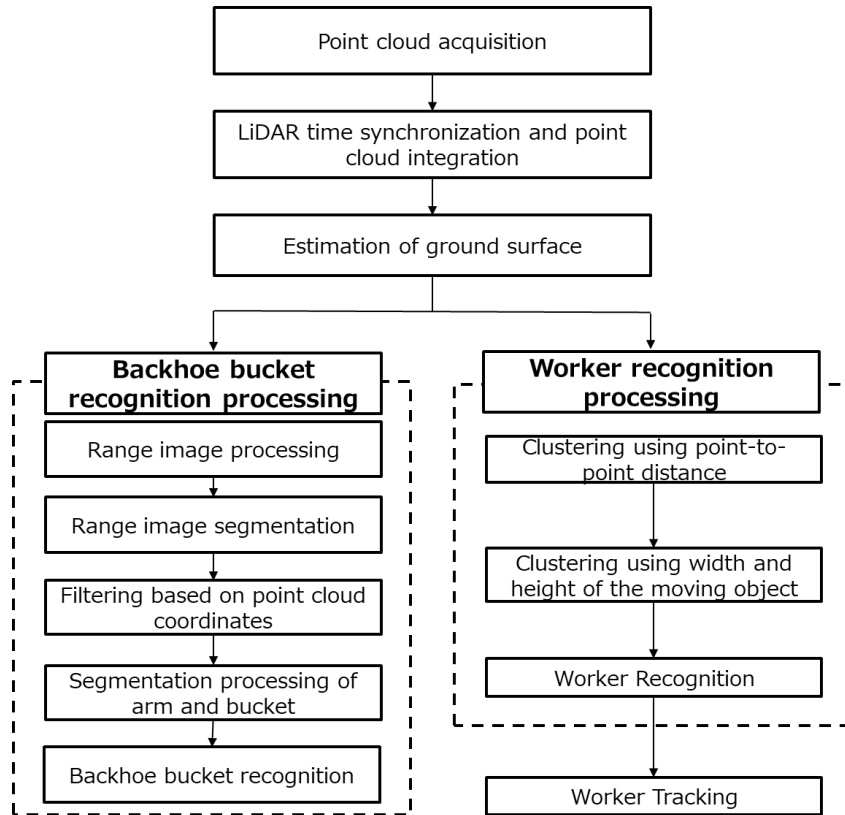

Figure 1. Proposed methodology

The object recognition process in this study consists of the following preprocessing steps: time synchronization of horizontal and vertical LiDAR, integration of the point clouds acquired by each LiDAR, and estimation of the ground surface using the RANSAC algorithm. Next, labeling is applied to each object using the range image generated from the point cloud. Subsequently, to extract only the point cloud of the bucket of the construction machine, the arm and bucket of the machine are segmented. In parallel with the bucket extraction, the position and behavior of the worker in the construction space are estimated by a motion (worker) recognition process consisting of clustering point clouds based on Euclidean distance and a clustering process using the width and height of the moving object. The same ID is assigned to the same worker in each scene by applying the tracking process.

2.1 Point Cloud Integration

To integrate the coordinate space (space-time) of the point clouds acquired by the horizontal LiDAR and vertical LiDAR, the GPS time is first recorded at the time of point cloud acquisition, and this information is used to synchronize the two LiDAR systems. The vertical LiDAR is mounted at a 90° tilt for vertical scanning, so the point clouds acquired by the vertical LiDAR are corrected for rotation. After the rotation correction, the coordinate space of the point cloud is integrated using the offset values measured between the LiDARs when they were mounted.

2.2 Range Image Processing

Imaging the point cloud facilitates labeling of the point cloud for bucket recognition. In this study, a range image is generated with LiDAR channel information in the line direction and scanning direction in the column direction. The information contained in the range image includes point cloud coordinates, reflection intensity values, and point cloud processing results, which are managed as layers (multiple images). In addition, the range images generated by the range image processing in this study include a distance image using the distance measurement values of each point, a distance

edge image using the difference in distance measurement values between adjacent pixels, a region segmentation image of the distance image using the distance edge image, and a label image by labeling the region segmentation results.

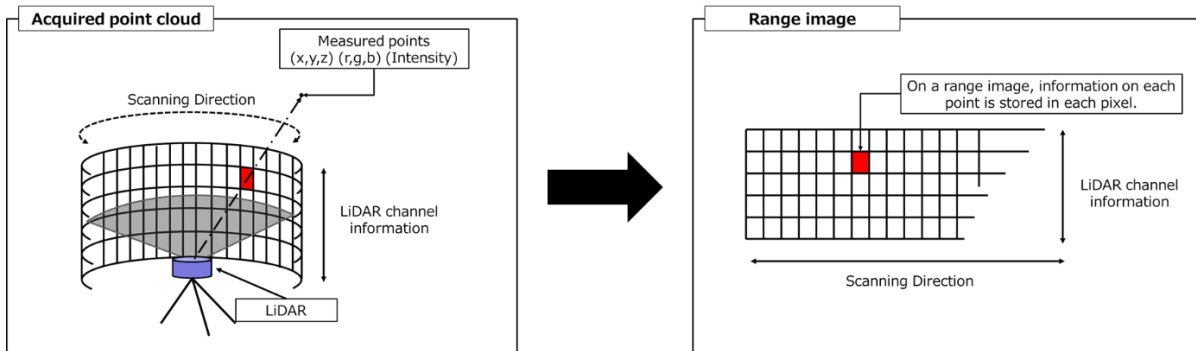

Figure 2. Overview of the range images

2.3 Labeling of Point Cloud

On the label image generated by labeling the region image in range image processing, the point clouds are also labeled in conjunction with the distance image generated in range image processing, but labels related to geographic objects are not assigned. Therefore, labels related to geographic objects are added using their relative positional relationship with the construction vehicle. In this section, we categorize the objects into three types: objects below the machine's running surface (e.g., buried pipes and steel sheet piles), objects in front of the machine (e.g., bucket and arm of the machine), and other objects (e.g., workers, dump trucks, buildings). Figure 3 shows a conceptual diagram of the target area of the point cloud in front of the construction vehicle.

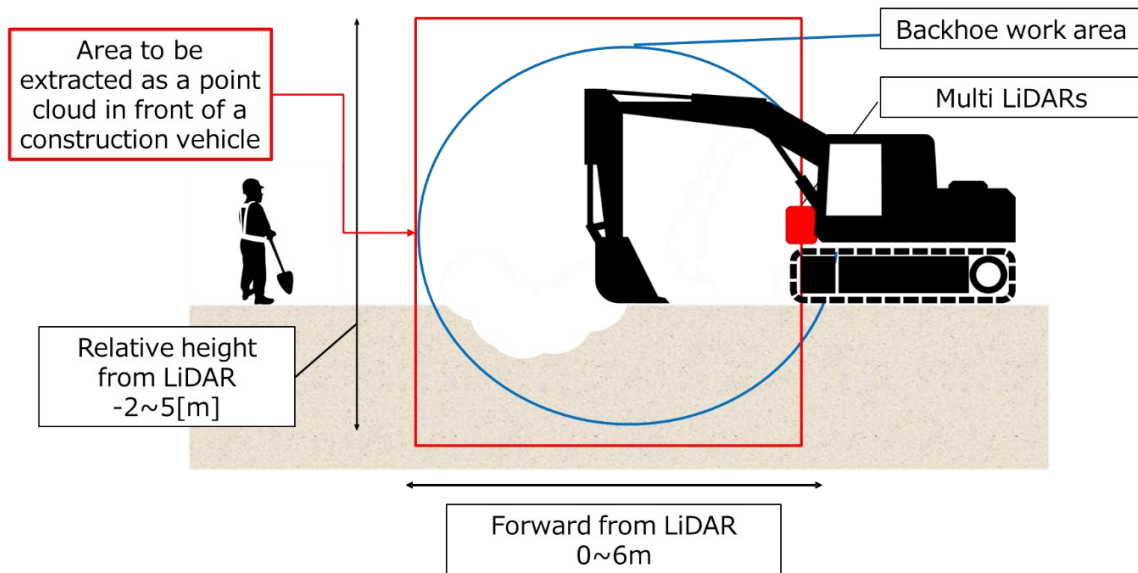

Figure 3. Target area of the point cloud in front of a construction vehicle

2.4 Segmentation Processing of Arm and Bucket of the Backhoe

To extract the point cloud of the backhoe bucket, it is necessary to resegment the arm and bucket from the point cloud labeled as the geographic feature in front of the construction vehicle at close range. Because the arm and bucket of a backhoe are connected as a single geographic feature, they are given the same label in the label image. Therefore, the arm and bucket are divided using a previously prepared point cloud (template model). The model point cloud used to divide the bucket is the point cloud data manually extracted only for the bucket from the data acquired in the experiment. In this study, the iterative closest point (ICP) algorithm, a point cloud registration method, is applied to the bucket segmentation using the point cloud labeled as a bucket (Figure 4). The ICP algorithm is used to align the point cloud with the previously prepared point cloud of the bucket, and the point cloud is extracted as the point cloud in front of the construction vehicle. Then, only the point cloud of the bucket is extracted from the point cloud in front of the construction vehicle using the coordinate values of the point cloud of the bucket after alignment.

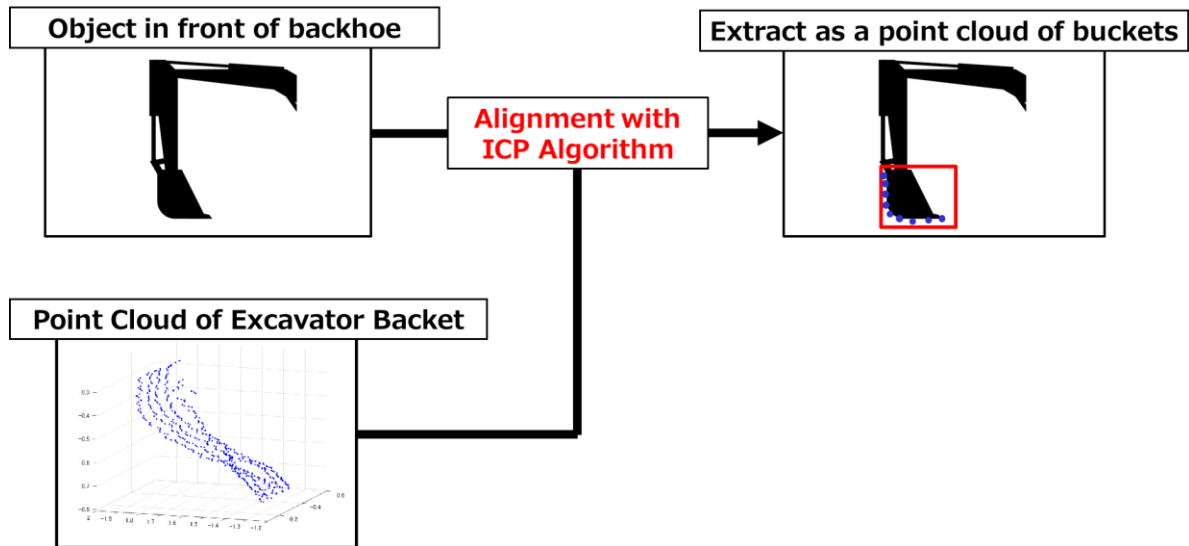

Figure 4. Extraction of a bucket from the point cloud of a construction vehicle

2.5 Worker Recognition Processing

For worker recognition, the points are segmented into clusters by setting the minimum Euclidean distance between points in different clusters and the minimum number of points required to be recognized as a single cluster (Figure 4). Then, threshold values for the width (ΔW) and height (ΔH) of each cluster are set, and only clusters that meet the threshold values are extracted as workers (Figure 5).

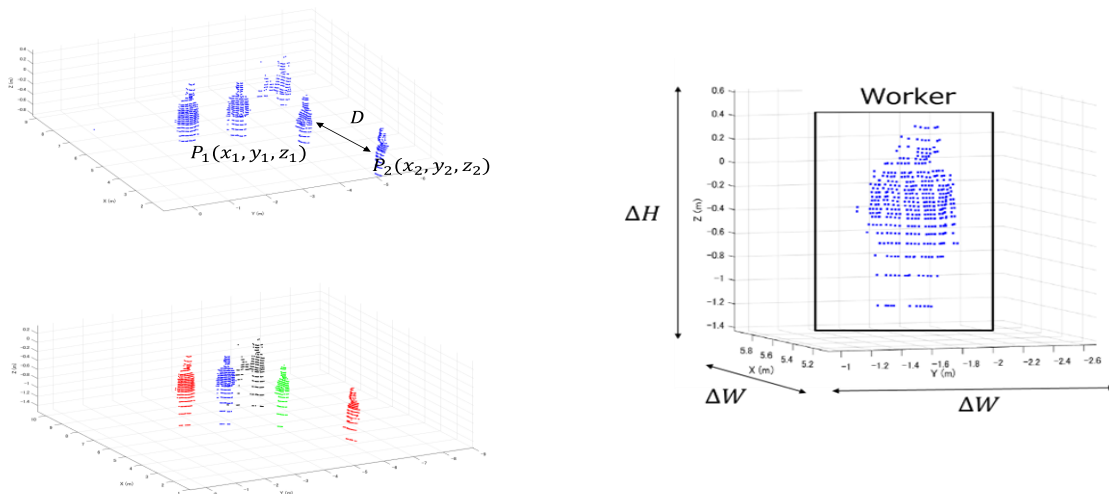

Figure 5. Conceptual image of clustering using Euclidean distance
 (Upper left: acquired point cloud, Lower left: clustering points using Euclidean distance,
 Right: clustering points using cluster width and height)

2.6 Worker Tracking Processing

Because the worker recognition process applies sequential processing to each scene, it is independent of the scenes before and after it. Therefore, the tracking process is used to establish the continuity of the worker's time series. In addition, the time-series point cloud acquired by LiDAR from a construction vehicle with turning and moving includes rapid horizontal rotation. Therefore, in the tracking process in this study, simultaneous localization and mapping (SLAM) processing is applied to reconstruct the time-series point cloud with the amount of horizontal rotation corrected. However, only the amount of horizontal rotation is corrected in this study because the amount of translational movement caused by the caterpillar movement of a construction vehicle in a construction space is only a few centimeters. For the tracking of workers, the time-series point cloud with horizontal rotation correction is used, and the search range of the worker in the tracking process is set to the center position of the worker in the previous scene according to the range in which the moving object is likely to move during one scan.

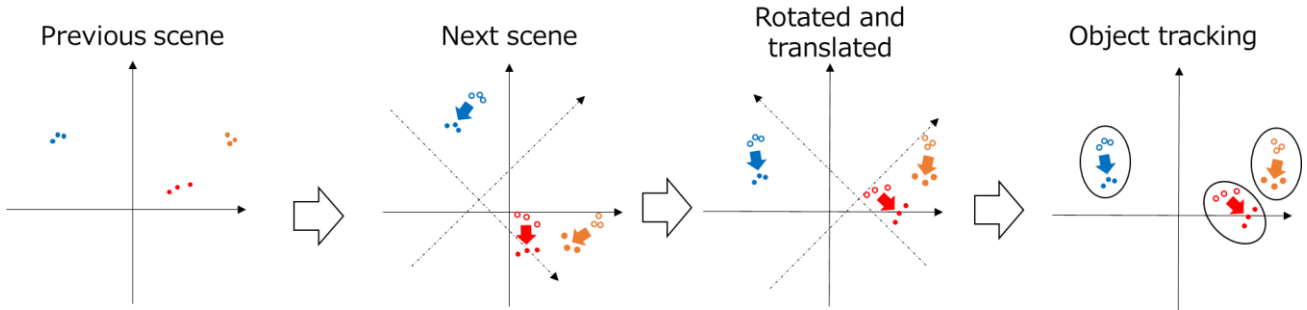

Figure 6. Worker tracking using SLAM

3. EXPERIMENT

In the experiments, a simulated construction space (Figure 7) was prepared to reproduce actual construction work such as excavation, piping, and backfilling performed by a backhoe and workers. Horizontal LiDAR (VLP-32C, Velodyne) and vertical LiDAR (VLP-16, Velodyne) were mounted in front of the backhoe operator's seat to acquire time-series point clouds (280 million points) of 4000 scenes (about 7 min).



Figure 7. Simulated construction space



Figure 8. Mounted LiDARs

4. RESULTS

Figure 9 shows the point clouds of an arbitrary scene acquired by horizontal LiDAR and vertical LiDAR in this experiment. Figure 10 shows the classification results of the point clouds.

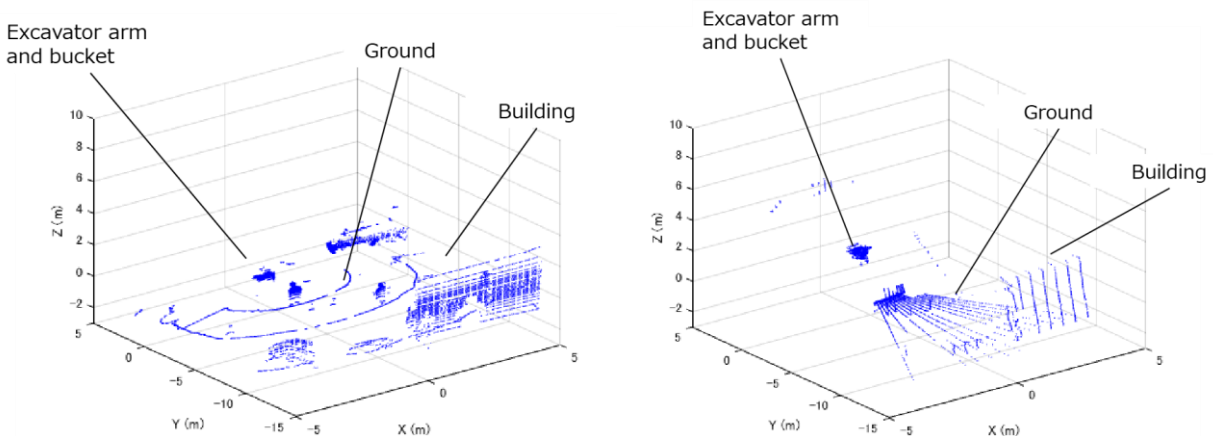

Figure 9. Acquired point cloud (Left: horizontal LiDAR, Right: vertical LiDAR)

The integration results of the point clouds acquired by vertical and horizontal LiDAR and the results of object recognition applied to the integration results of the point clouds are shown in Figure 10.

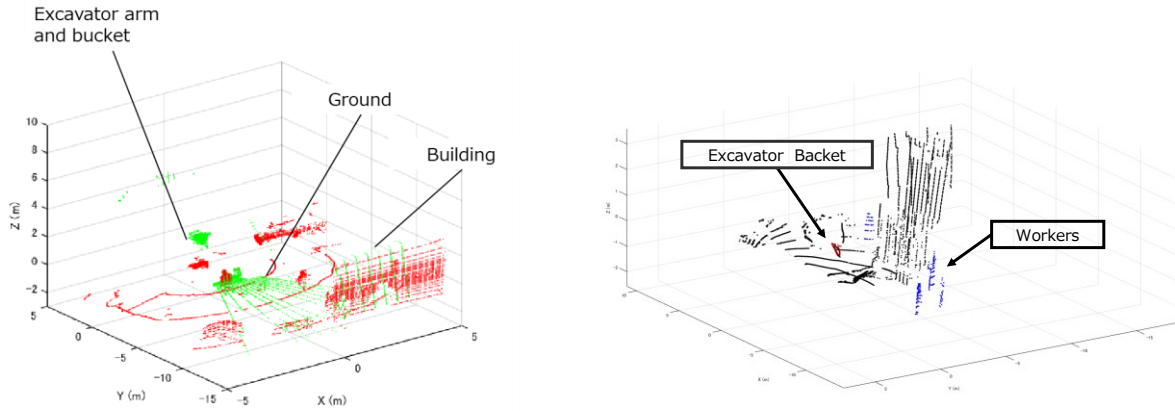
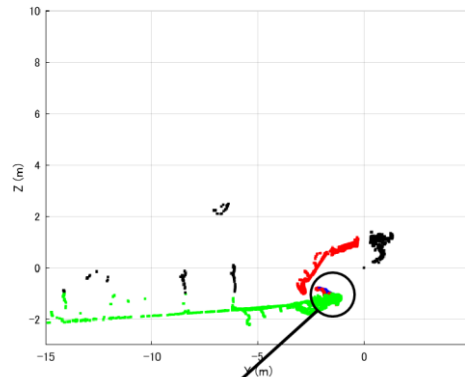

Figure 10. Result of point cloud processing
(Left: Point cloud integration result, Right: worker recognition result)

5. DISCUSSION

We confirmed that the point cloud integration of horizontal LiDAR and vertical LiDAR can complement the point cloud acquisition in areas where it is difficult to acquire point clouds independently. In addition, as shown in Figure 10, we confirmed that the proposed method can extract buckets and workers. However, as shown in Figure 11, there were some scenes where the bucket could not be recognized accurately. The reasons for the failure of bucket recognition include the fact that the point cloud of the bucket could not be acquired when it moved out of the LiDAR's field of view, such as in a pit during excavation, and that the search for corresponding points in the ICP algorithm was not performed accurately.



The bucket is aligned with the area that could not be extracted as a ground surface.

Figure 11. Example of failed bucket extraction

In the extraction of workers, we confirmed that some scenes were not extracted accurately. In the case shown in Figure 12, the dump truck and the worker are very close to each other, so the distance between the worker's point cloud and the dump truck's point cloud becomes small, and when clustering using Euclidean distance, the clusters are segmented as the same.

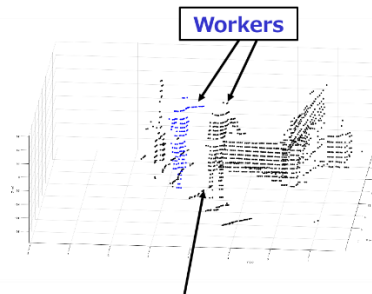

Two workers can be visually identified, but only one is recognized.

Figure 12. Example of failed worker extraction

6. CONCLUSION

In this study, we developed a methodology for integrating point clouds acquired by two LiDARs from construction vehicles and a methodology for recognizing backhoe buckets and recognizing and tracking workers using the results of the integration. Through experiments, we confirmed that the combination of horizontal and vertical LiDAR can acquire point clouds of the bucket behavior and bucket work area, which are difficult to acquire by horizontal scanning alone. We also confirmed that the proposed method can extract the bucket and workers in the construction space by object recognition. In the future, it is necessary to add a function to identify workers and visualize their hazardous behaviors.

REFERENCES

- Kajita, H., Ito, S., Hashimoto, T., 2017. Efforts to Improve Productivity in Unmanned Construction Technology. *Civil Engineering Materials*, 59 (1), pp. 30-35.
- Kondo, T., Aoki, H., Miyazaki, H., 2011. Current Status and Future of Unmanned Construction in the Construction Industry. *Taisei Corporation Technical Center Report*, 44 (19), pp. 1-7
- KAJIMA CORPORATION., 2020. Challenges and Future of the Civil Engineering Industry, Retrieved September 15, 2021, from https://www.kajima.co.jp/news/digest/jul_2020/feature/01/index.html
- Nakagawa, M., Namie, H., Taguchi, M., 2021, Motion Identification in Construction Space by LiDAR and BLE Ranging, *Journal of Applied Surveying*, Vol.32, 10 pages.
- Yokota, T., Kuroda, Y., 2014, Human Recognition by Extracting Shape Features from LIDAR Data, *Abstracts of Lectures on Robotics and Mechatronics*, 3P-K04. 4 pages.